

MIGHTY MULE[®]

ACCESS CONTROLS

IMPORTANT: Allow the intercom base unit's battery to charge for 12 hours before using the system for the first time. See page 7 for details.



Base Unit



Keypad Unit

Wireless Gate Entry Intercom

Instructions for Wireless and Wired Installations

Crystal clear two-way communication up to 500 feet wireless or 1000 feet with extended antenna.

Thank you for purchasing the GTO Wireless Gate Entry Intercom. Please read the directions carefully and completely before installing.

SAFETY NOTE: Never install the keypad portion of this unit where a person can reach through the gate to activate it, or where a person can touch the gate while activating the keypad. The recommended minimum distance between the gate and keypad is 10 ft.

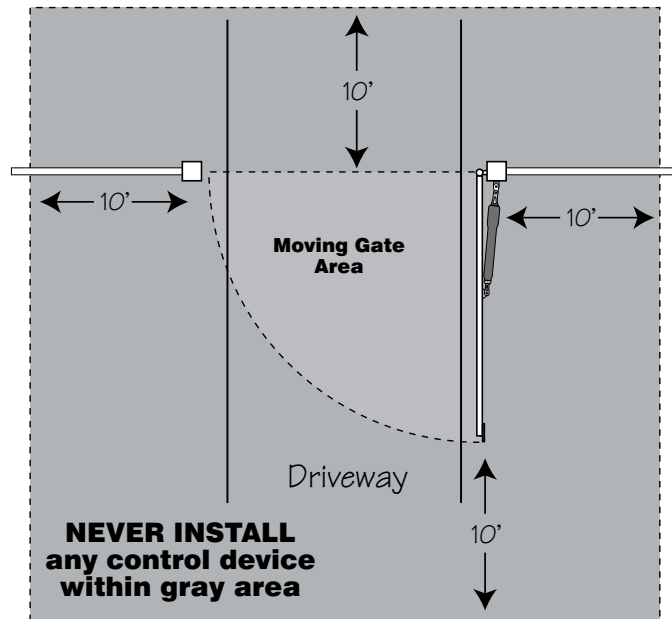

Features of the Intercom/Keypad

The INTERCOM has two separate units. The KEYPAD (outside unit) should be mounted outside the gate allowing the driver of the vehicle approaching the property to press the CALL button from their vehicle. The BASE (inside unit), with its rechargeable battery, can be plugged into any 110 Volt AC outlet for use while charging. It can also be disconnected from the charger allowing it to go any where within range for convenience. Up to three additional BASES can be added for convenience in different locations throughout the house.

When someone without an access code approaches the gate, they can press the CALL button on the keypad which will ring the BASE unit inside the house. To answer the CALL, the person inside presses and holds the ANSWER button to talk to the person at the gate, releasing the ANSWER button to listen. To allow the person calling to open the gate, the GRANT PERMISSION button must be pressed. Then the person at the gate can press any number key on the KEYPAD to open the gate. The "END CALL" button terminates the calls and the "ON/OFF" switch can be used to conserve power when using unit on battery.

Up to 25 different personal entry codes may be programmed into the KEYPAD, allowing you to give different temporary and permanent entry codes to different users. For example, you can give a delivery person their own temporary entry code, which you can easily change after he has made the delivery. This will prevent him from being able to regain access, while still allowing those to whom you gave permanent entry codes full access.

After entering a valid code, pressing any key on the KEYPAD while the gate is opening will stop the gate; pressing any key while the gate is stopped will cause the gate to reverse direction. The KEYPAD will not affect the auto-close setting of your gate opener system.

The KEYPAD number pad will light up and the unit will beep at the press of any key. The KEYPAD memory will recognize your entry code in a string of up to 20 digits. If it finds the correct sequence, it will activate the gate opener. As a security feature, the keypad will shut down for 40 seconds if it does not find the correct code sequence within a 20 digit string. This will discourage an unauthorized person from trying to use random numbers to access your property.

Your entry codes will remain stored in memory even when the batteries go dead. The KEYPAD will remember your entry codes as long as you don't press the RESET button.

IMPORTANT: In areas of high radio frequency (RF) interference, the KEYPAD may need to be connected (hard wired) directly to the gate opener using 16 gauge (AWG) stranded, direct burial, low voltage wire (GTO part no. RB509 not included).

Also in areas of high radio frequency (RF) interference, the BASE unit may not communicate with the KEYPAD and will require extending the antenna from the KEYPAD closer to the house co-ax cable (RG59 or RG6 which is not included). See page 8 for details.

FCC WARNING: Changes or modifications to this unit not expressly approved by the party responsible for compliance could void the user's authority to operate the equipment.

NOTE: This equipment has been tested and found to comply with the limits for a Class B digital device, pursuant to Part 15 of the FCC Rules. These limits are designed to provide reasonable protection against harmful interference in a residential installation. This equipment generates, uses and can radiate radio frequency energy and, if not installed and used in accordance with the instructions, may cause harmful interference to radio communications.

However, there is no guarantee that interference will not occur in particular installations. If this equipment does cause harmful interference to radio or television reception, which can be determined by turning the equipment off and on, the user is encouraged to try to correct the interference by one or more of the following measures: • Reorient or replace the receiver antenna. • Increase the separation between the equipment and the receiver. • Connect the equipment into an outlet on a circuit different from that to which the receiver is connected. • Consult the dealer or an experienced radio/TV technician for help.

Keypad Description

Keypad - Front

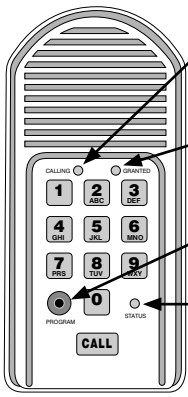

- CALLING Light:**
LED is RED when calling and turns GREEN when call is answered.
- GRANTED Light:**
LED turns GREEN when access permission is granted.
- PROGRAM button:**
Used to program access codes.
- STATUS Light:**
This led will blink once when any key is pressed and provides visual feedback during access code programming.

Keypad - Inside

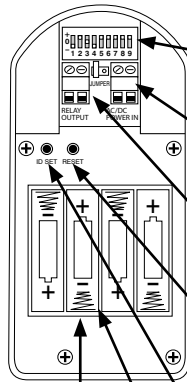

- DIP Switches:**
Match these switches to your remote transmitter to program the keypad.
- Power Input:**
Used to connect keypad to gate opener for continuous power supply.
- Relay output:**
Used to connect the keypad to gate opener in hard-wired applications.
- RESET button:**
Pressing this button for 2 seconds will reprogram the keypad to factory settings. All codes are deleted. Default master code is 1234.
- ID SET button:**
This button is used only when there is another pair of GTO wireless intercom units nearby causing interference.
- Battery Holder:**
Use 4 AA batteries if hard-wired power supply is not used. If external power source is used the 4 AA batteries will provide a back-up power source.

Installing Batteries

NOTE: Four (4) AA batteries (not included) are required to power the keypad. If an external DC power supply such as the gate opener's power source is used, the AA batteries will act as a back up. Low voltage wire from the gate opener battery must be connected to the POWER IN terminals on the keypad control board.

Step 1: Remove the two screws from the bottom of the keypad and separate the keypad from its housing.

Step 2: Install four (4) AA batteries (not included).

Wireless Installation of the Keypad

NOTE: For wireless applications, the keypad must be in the line of sight of the gate opener receiver and the distance from the keypad to the opener's receiver should not exceed 50 ft. Always test the keypad range before permanently mounting it. A metal housing or metal object could cause interference.

Step 1: Mount the keypad cover using the screws provided. Set the keypad DIP switches to match your entry transmitter's DIP switch settings.

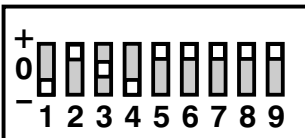

NOTE: If you have not changed your opener's transmitter code from the factory setting, see the "Setting Your Personal Transmitter Code" section in the gate opener's manual then set the keypad DIP switches to match the new transmitter DIP switch setting.

Step 2: Slide the keypad into the cover and secure with the small screws provided.

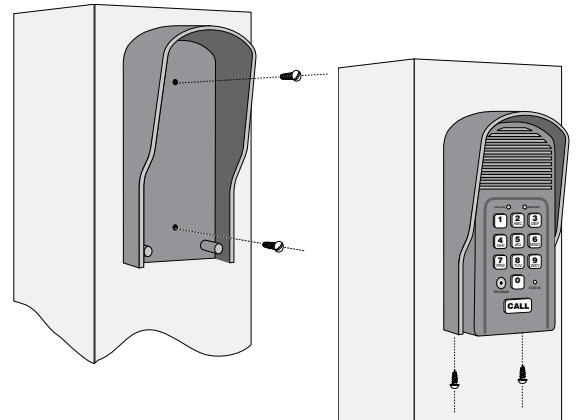

Wired Installation of the Keypad

NOTE: If you also plan to power the keypad with the gate opener's battery and hard wire the communication between the keypad and the gate opener, run two pairs of wires as described below. One pair to hard-wire the keypad to the gate opener's control board and the other pair to connect the keypad to the gate opener's battery.

Step 1: Turn the gate opener's power switch OFF. Use 16 gauge (AWG) stranded, direct burial, low voltage wire (part no. RB509) to connect the keypad to the opener control board. Run wire through PVC pipe from the ground to keypad and from the ground to the opener control board to protect the wire from lawn mowers or grazing animals.

Determine how the wire will enter the keypad (i.e. from the back through a hole drilled in the mounting post or running the wire on the surface of the post). Remove the small rectangular knock-out on the back of the keypad cover and pull the wire into the cover. Then mount the cover to the post using the screws provided.

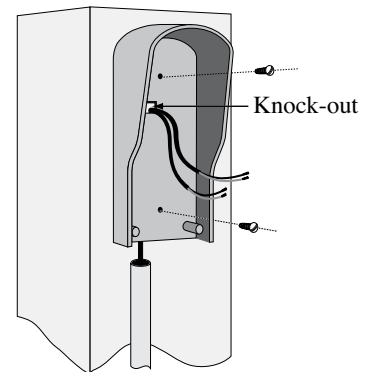

Step 2: For hard-wired communication between the keypad and gate opener, using 16 gauge (AWG) stranded, direct burial, low voltage wire (part no. RB509) strip the wires back 3/16" and attach the wires to the terminal block marked RELAY OUTPUT on the keypad control board as shown to the right. Connect the other end to the opener's control board as shown in Control Board Connections section below.

To wire the power supply to the keypad, attach the wires to the AC/DC POWER IN terminal on the keypad control board as shown to the right. Connect the other end to the opener's battery - one end to the POSITIVE (RED) pole and the other to the NEGATIVE (BLACK) pole.

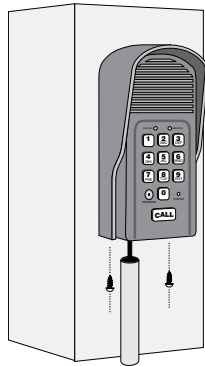

NOTE: For a hard-wired application the jumper between the two terminals on the keypad control board must be connected (ON) as shown. This will disable the 318 MHz RF transmitter.

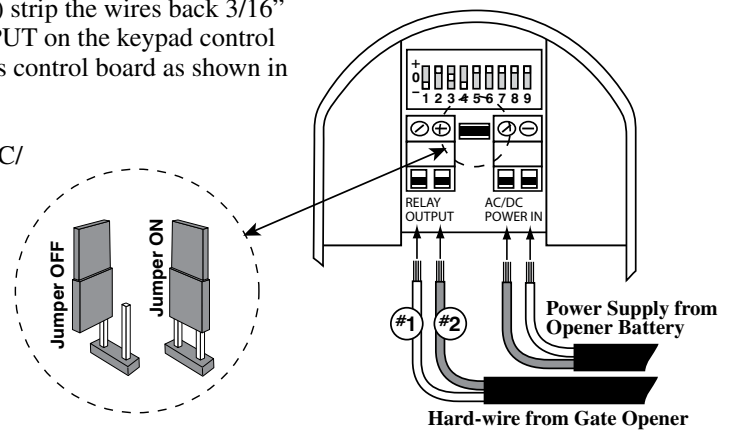

Step 3: Slide the keypad into the cover and secure with the small screws provided.

Step 4: Turn the power to the opener OFF. Remove the opener control board cover and feed enough of the low voltage wire from the keypad through a strain relief to reach the gate opener control board terminals.

Step 5: Attach the wires from the keypad to the opener control board terminal blocks as shown below.

Step 6: Replace the control board cover and turn the power switch ON. Test the keypad by entering 1 2 3 4.

Step 7: Program your 'Personal Master Code' and any additional entry codes (for a total of 25 entry codes). See Programming the Keypad section.

Control Board Connections

NOTE: If your control board doesn't look like any of these diagrams, please call GTO Technical Service at 1-800-543-1236 or 850-575-4144 for additional support.

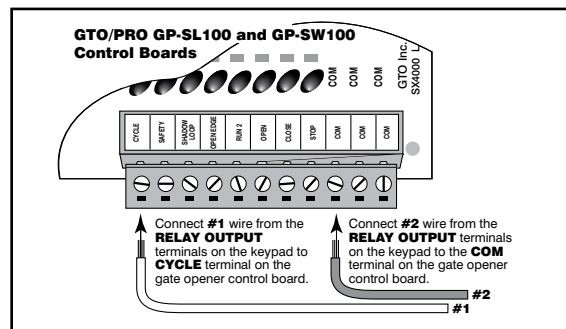
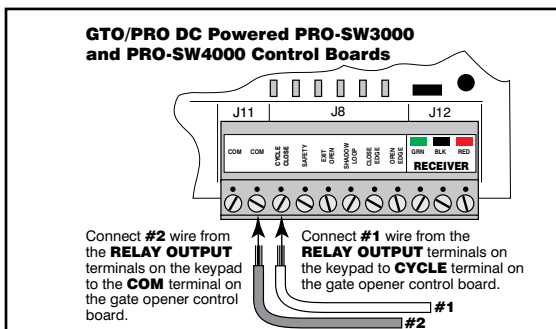
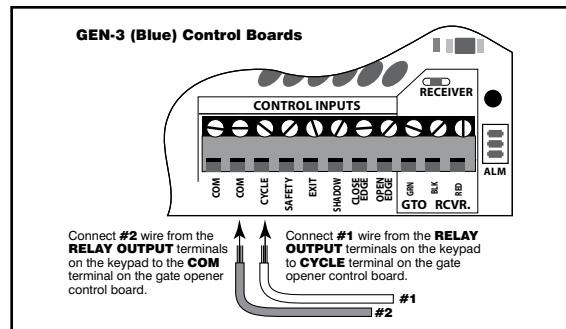
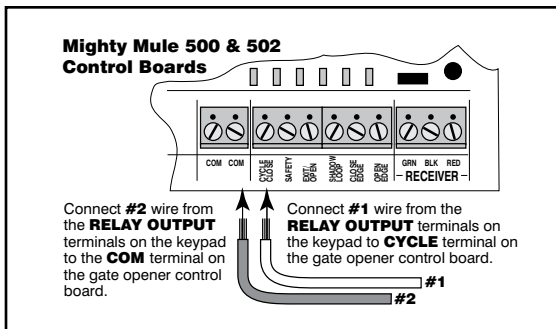
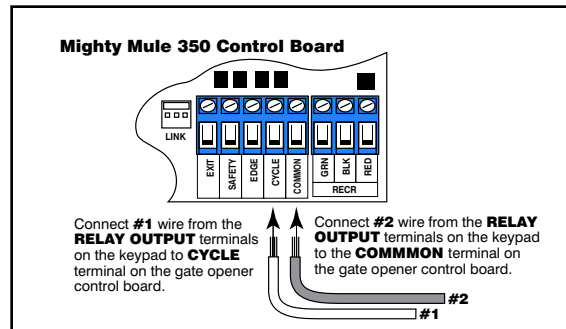
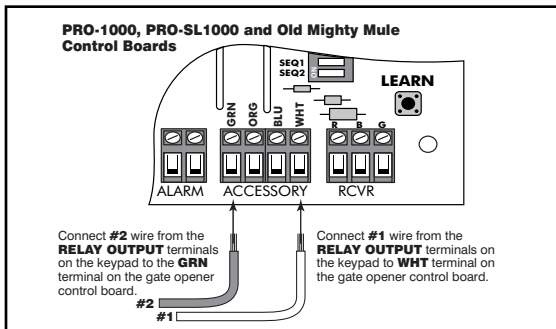

Programming the Keypad

Programming Interface:

- All codes are four (4) digits in length.
- Entry code is a four (4) digit code needed to activate the gate.
- Master Code is needed to add, remove or reset entry codes.
- Master Code also functions as the entry code under normal operation.
- Factory default Master Code is 1234.
- STATUS light should blink and beeper should beep (once) whenever any button is pressed.
- If more than 10 seconds elapsed between key presses the unit returns to normal (idle) operating mode.
- Keypad can only enter program mode from sleep mode (keypad is turned OFF).
- Keypad will beep three times before going into sleep mode.

Program New Master Code:

- Press and release PROGRAM button.
- Enter the old Master Code then press and release PROGRAM button.
- Enter 0, 6 then press and release PROGRAM button
- Enter the new Master Code then press and release PROGRAM button.
- Enter the new Master Code then press and release PROGRAM button again for confirmation.
- Beeper beeps 3 times to confirm that the new Master Code is accepted.

NOTE: If the Master Code is not a matched pair or error occurs, (i.e. if the entry code is NOT a 4-digit code) the STATUS light will flash rapidly and the beeper will sound for 2 seconds before returning to normal operation with old Master Code.

Example: Key press sequence to change old Master Code from 1 2 3 4 to 3 1 2 1

● 1 2 3 4 ● 0 6 ● 3 1 2 1 ● 3 1 2 1 ●

The round black dot is the 'PROGRAM' button.

Program (Add) New Entry Code:

- Press and release PROGRAM button.
- Enter the Master Code then press and release PROGRAM button.
- Enter 0, 2 then press and release PROGRAM button.
NOTE: If memory is full (all 25 locations are already programmed) the STATUS light will flash rapidly and the beeper will sound for 2 seconds before returning to normal operation without saving.
- Enter the new Entry Code then press and release PROGRAM button.
- Beeper beeps 3 times to confirm that the new Entry Code is accepted.
NOTE: If the code is NOT 4-digits in length or an error condition has occurred. The STATUS light will flash rapidly and the beeper will sound for 2 seconds before returning to normal operation without saving.

Example: Key press sequence to add '3456' as a new entry code. (1234 is the Master Code)

● 1 2 3 4 ● 0 2 ● 3 4 5 6 ●

The round black dot is the 'PROGRAM' button.

Program (Add) New Temporary Entry Code:

- Press and release PROGRAM button.
- Enter the Master Code then press and release PROGRAM button.
- Enter 8, and any number between 1 thru 7 then press and release the PROGRAM button. The number 1 thru 7 indicates the number of days after which the code will be automatically removed from memory
NOTE: If memory is full (all 25 locations are already programmed) or an invalid entry is detected, then an error condition has occurred. The STATUS light will flash rapidly and the beeper will sound for 2 seconds before returning to normal operation without saving.
- Enter the new Entry Code then press and release PROGRAM button.
- Beeper beeps 3 times to confirm that the new Entry Code is accepted.
NOTE: If the code is NOT 4-digits in length or an error condition has occurred, the STATUS light will flash rapidly and the beeper will sound for 2 seconds before returning to normal operation without saving.

Example: Key press sequence to add "3456" as a new entry code that will remain valid for 2-days only. (1234 is the Master Code)

● 1 2 3 4 ● 8 2 ● 3 4 5 6 ●

The round black dot is the 'PROGRAM' button.

Example: Key press sequence to add "3456" as a new entry code that will remain valid for 7-days only. (1234 is the Master Code)

● 1 2 3 4 ● 8 7 ● 3 4 5 6 ●

The round black dot is the 'PROGRAM' button.

Delete An Entry Code:

- Press and release PROGRAM button.
- Enter the Master Code then press and release PROGRAM button.
- Enter 0, 3 then press and release PROGRAM button.
- Enter the Entry Code to be deleted then press and release PROGRAM button.
- Beeper beeps 3 times to confirm that the new Entry Code is deleted.

NOTE: If no matching code is found or the code is NOT 4-digit in length, then an error condition has occurred. The STATUS light will flash rapidly and the beeper will sound for 2 seconds before returning to normal operation without saving.

Example: Key press sequence to delete entry code '3456' from memory. (1234 is the Master Code)

● 1 2 3 4 ● 0 3 ● 3 4 5 6 ●

The round black dot is the 'PROGRAM' button.

Delete ALL Entry Codes:

- Press and release PROGRAM button.
- Enter the Master Code then press and release PROGRAM button.
- Enter 0, 7 then press and release PROGRAM button.
- Beeper beeps 3 times to confirm that the All Entry Codes are deleted.

Example: Key press sequence to delete all entry codes from memory. (1234 is the Master Code)

● 1 2 3 4 ● 0 7 ●

The round black dot is the 'PROGRAM' button.

Normal Keypad operation:

- If the user enters a 4-digit code that is matched to one of the 25 stored codes, the STATUS light should blink twice and the beeper should beep twice to confirm that a matched code is entered.
- No more than 20 key presses are allowed to obtain the 4-digit entry code.

Example:

1234 is one of the codes stored in one of the memory location.

The user can enter 'x1234' or 'xxxxxxxxxxxxxxxx1234' and the gate should be activated (x is any key). If more than 20 key presses is entered without matching one of the codes, then the STATUS light should be flashing rapidly and no entry will be accepted for the next 40 seconds. The user must not enter any code for at least 40 seconds before the unit returns to normal operation. Otherwise it remains in this 'lock-down' mode. **Once the user enters a matched code, any subsequent key press within the next 40 seconds will re-activate the keypad.**

Intercom Description

Intercom - Face

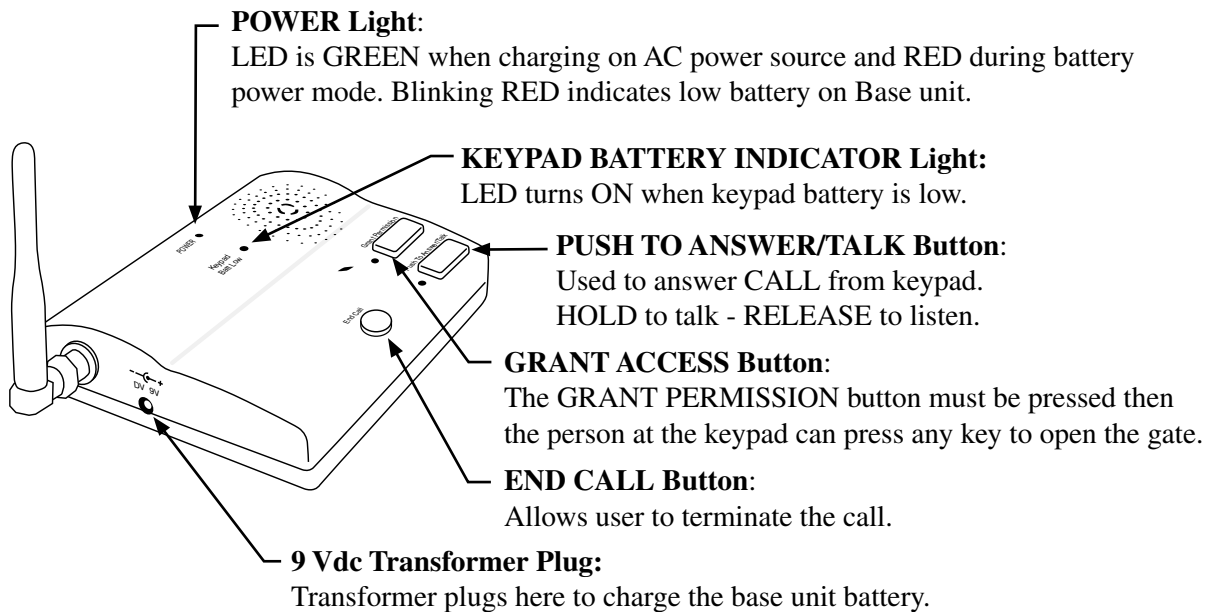

Intercom - Bottom

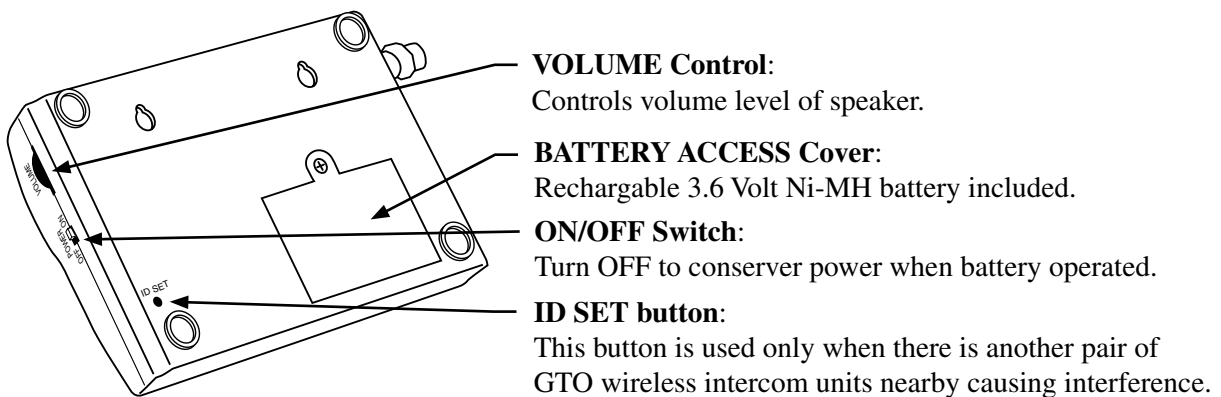

Intercom Base Unit Installation

Connecting the Battery

Remove the battery access cover using a small phillips head screwdriver. Plug the rechargeable Ni-MH battery into the receptacle inside the battery compartment. See diagram to the right. When this is done, replace the battery access cover.

IMPORTANT: Allow the intercom base unit's battery to charge for 12 hours before using the system for the first time. See page 7 for details.

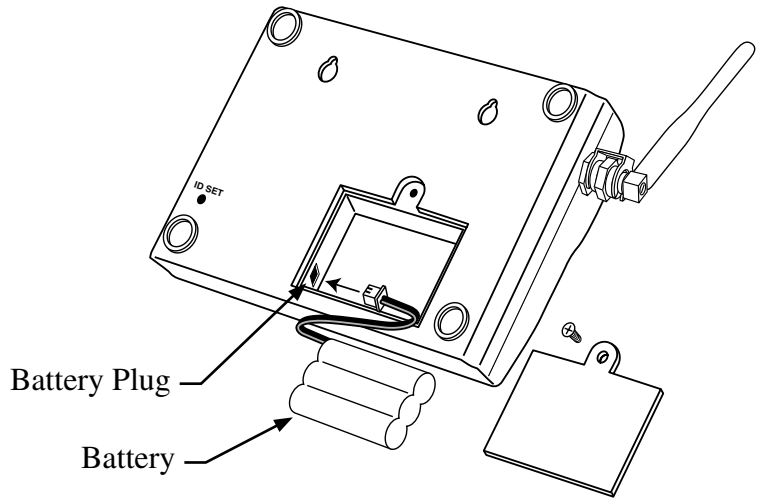

Connecting the Transformer

IMPORTANT: Once connected, allow the intercom base unit's battery to charge for 12 hours before using the system for the first time.

Find a convenient location near an approved outlet to mount or place the intercom. Plug the transformer into the AC outlet and connect it to the intercom's power jack marked DC 9V.

If you are mounting the intercom on the wall, use the template on the last page of this manual to place screws.

The intercom can be disconnected from the transformer and used as a battery powered unit. It can be moved to any convenient location, i.e. bedroom, patio, or garden area.

IMPORTANT: When the Intercom unit is ON it is in the receive mode. When plugged into the transformer it is constantly charging the battery. The battery will last approximately four (4) hours when unplugged from the transformer. You can turn the unit OFF to conserve battery power but it will not receive a signal when OFF.

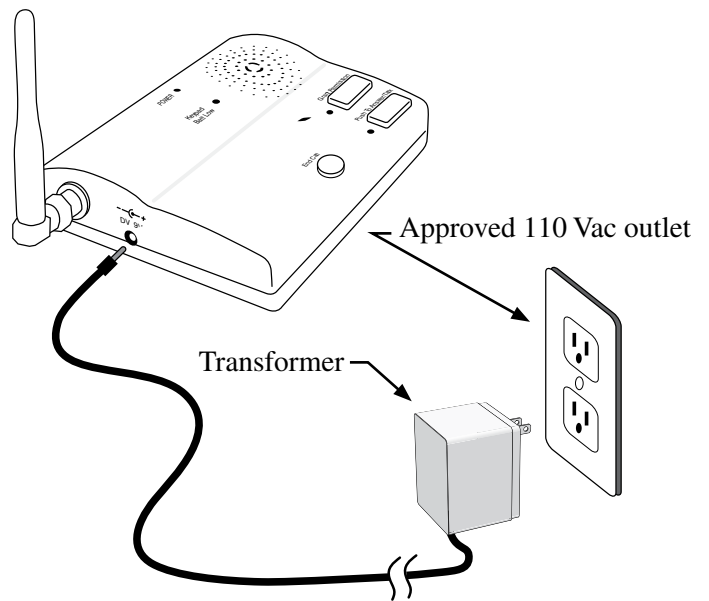

Intercom ID Codes

The Base and Keypad that came in this kit are programmed at the factory to communicate with each other, and do not need the ID Codes programmed. This Base is the MASTER or #1 unit.

Adding Additional Base Units

If you have purchased additional Base units to enhance your system, each additional unit's ID Code must be programmed into the Keypad so they can communicate. Follow the steps below to set the ID codes.

Batteries must be installed and the units turned ON.

1. Press and release the "ID SET" button on the Keypad.
2. Press the number on the Keypad that corresponds to the Intercom you are adding or changing. You will hear the number of beeps corresponding to the number you pressed.
For Example: If you are adding a third Intercom to the system PRESS #3. The Keypad will beep THREE times.
3. Press the "ID SET" button on the Intercom approximately 2 seconds then release. You will hear THREE beeps from the Intercom and THREE beeps from the Keypad, which means the ID Codes are set.

IMPORTANT: Place Intercoms through the home or office with at least 10 feet between them to prevent interference.

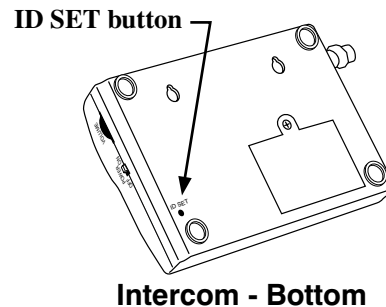
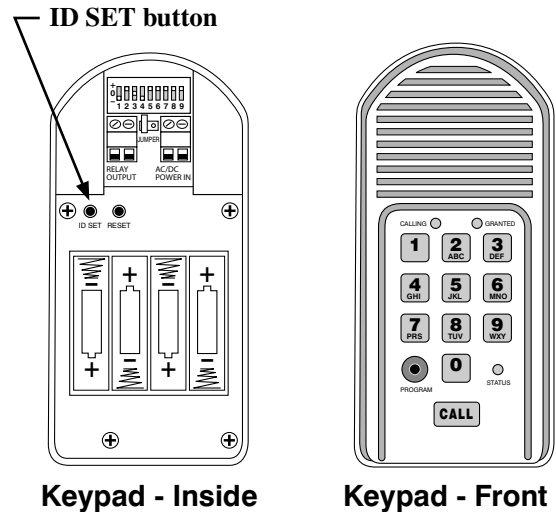

Extending Antenna Range

In areas of high radio frequency (RF) interference, the intercom may not work as a wireless system. In these areas the keypad antenna will need to be extended (run closer to the house) using RG59 or RG6 co-axial cable, which is the same type of cable used for cable TV.

You will need enough co-ax cable to run from the keypad location to a convenient location close to the house, but not closer than 10 feet from the intercom base unit. You will also need two F-connectors for each end of the co-ax cable and a F-connector female adapter to connect the antenna from the keypad to the end of the co-ax cable near the house. The co-ax cable and connectors can be found at hardware and electronics stores.

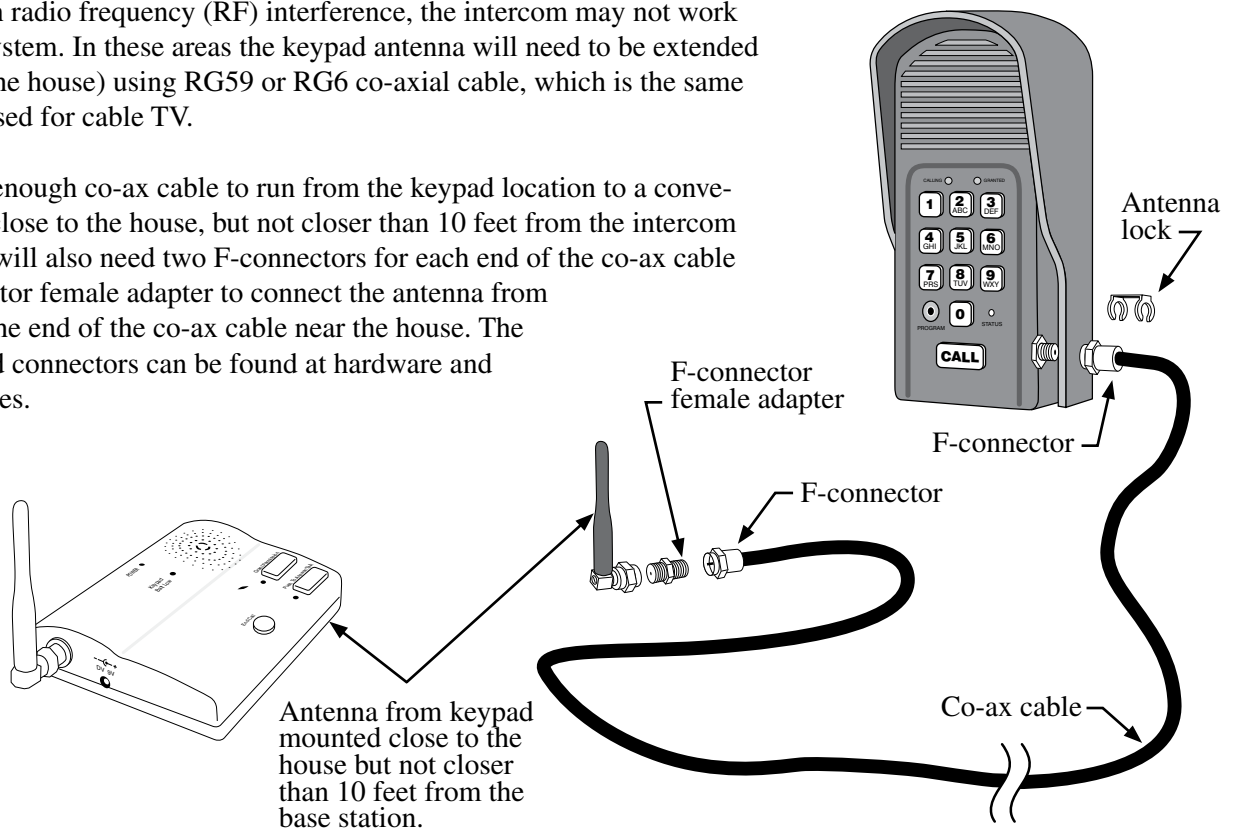

Run the co-ax cable in PVC conduit from the keypad at the gate to a convenient location at the house. A typical location might be on the side of the house by the garage. Attach a F-connector to each end of the co-ax cable. Remove the antenna from the keypad and connect the co-ax cable to the keypad as shown in the diagram above.

Connect the antenna to the other end on the co-ax cable using the F-connector female adapter and the F-connector and mount the antenna to the side of the house. The type of mounting hardware will depend on the type of siding on the house. Mount the antenna at least four (4) feet above the ground. See example to the right.

IMPORTANT: DO NOT run co-ax cable in same conduit with AC power or with-in 3 feet of AC power source. **DO NOT** mount the antenna to any metal buildings or metal post.

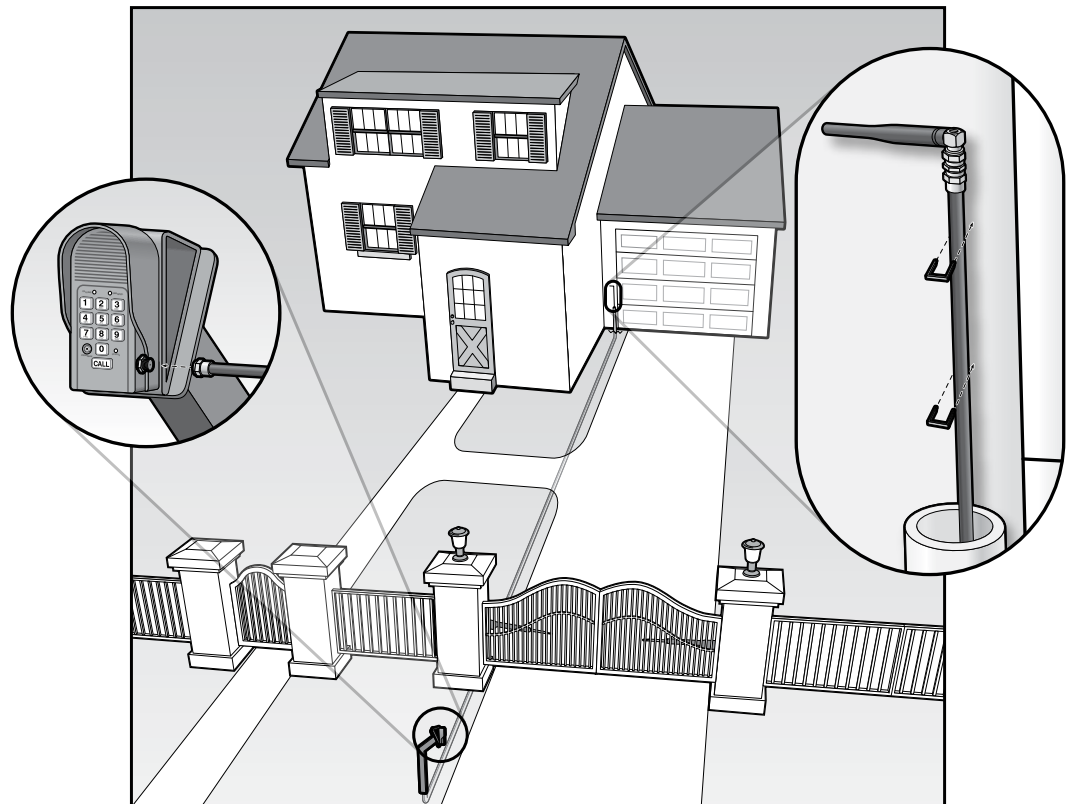

Test the System

IMPORTANT: The Base unit and the Keypad can not be within 30 feet of each other when operating. If units are closer than 30 feet the signal will be inconsistent as well as emit speaker feed back. Also, multiple Base units must be no closer than 10 feet from each other to prevent interference.

Have someone press the CALL button on the keypad at the gate. When the base unit inside the house rings, press the ANSWER button and talk to the person at the gate to check the connection and range. Then press the GRANT PERMISSION button and have the person at the gate press any key on the keypad to activate the gate.

Trouble Shooting

Make sure all connections are secure and correct.

Other electronic devices in the same area may interfere with the factory ID code. If the system does not communicate at all, reset the intercom/keypad ID code as follows.

RESET ID: This will require two (2) people.

1. Open the keypad and locate the “ID SET” button above the batteries.
2. Locate the “ID SET” button on the bottom of the intercom base unit.
3. Make sure the “antenna-to-antenna” distance between the keypad and the base unit is at least 30 feet.
4. Reset the MASTER Intercom base unit’s ID Code.

Batteries must be installed and the units turned ON.

- A. Press the “ID SET” button on the Keypad until you hear a beep, then release. This erases all stored ID Codes.
- B. Press the “ID SET” button on the MASTER Intercom for approximately 2 seconds then release. You will hear ONE beep from the Intercom and TWO from the Keypad, which means the ID Codes are reset.
- C. Test the system by pressing the CALL button on the Keypad to see if the Intercom receives the signal.

NOTE: If the system is now working you will need to reset any additional Intercom you have installed. See “Adding Additional Intercoms”.

IMPORTANT: Base units must be no closer than 10 feet from each other to prevent interference.

If all connections are correct and the ID SET change didn’t solve the communication problem, please call our Technical Service Department at 1-800-543-1236 Monday - Friday 8:00 am to 7:00 p.m. (ET).

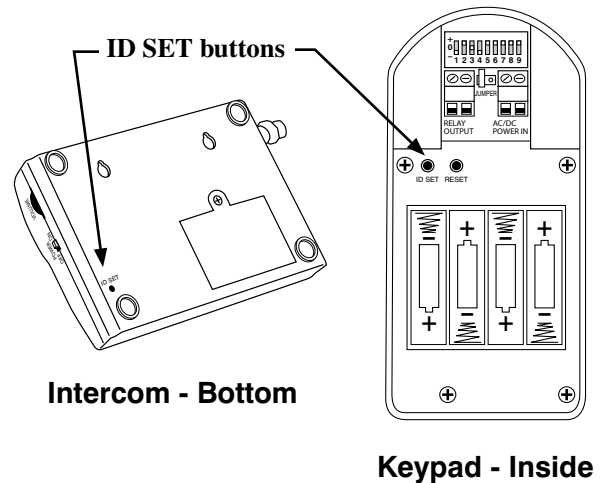

Hole Template for Mounting the Base Unit

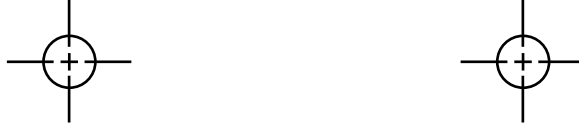

Limited One Year Warranty

GTO, Inc. gate opener accessories are warranted by the manufacturer against defects in workmanship for a period of one (1) year from the date of purchase, provided recommended installation procedures have been followed.

In the case of product failure due to defective material or manufacturer workmanship within the one (1) year warranty period, the accessory will be repaired or replaced (at the manufacturer's option) at no charge to the customer, if returned freight prepaid to GTO, Inc., 3121 Hartsfield Rd., Tallahassee, FL 32303. IMPORTANT: Call 850/575-4144 or fax 850/575-8950 for a Return Goods Authorization (RGA) number before returning goods to factory. Products received at the factory without an RGA will not be accepted. Replacement or repaired parts are covered by this warranty for the remainder of the one (1) year warranty period. GTO, Inc. will pay the shipping charges for return to the owner of items repaired.

The manufacturer will not be responsible for any charges or damages incurred in the removal of the defective parts for repair, or for the reinstallation of those parts after repair. This warranty shall be considered void if damage to the product(s) was due to improper installation or use, connection to an improper power source, tampering, or if damage was caused by lightning, wind, fire, flood, insects, or other natural agent.

After the one (1) year warranty period, GTO Inc. or one of its authorized service centers will make any necessary repairs for a nominal fee. Call GTO at 850/575-4144 for more information. This warranty gives you specific legal rights, and you may also have other rights which may vary from state to state. This warranty is in lieu of all other warranties, expressed or implied. NOTE: Verification of the warranty period requires copies of receipts or other proof of purchase. Please retain those records.

If you have any questions or concerns, please contact our Technical Service Department
Monday thru Friday 8:00 am to 7:00 p.m. (ET) at 1-800-543-1236 or 850-575-4144.
GTO, Inc. • 3121 Hartsfield Road • Tallahassee, Florida 32303
Telephone (850) 575-0176 • Fax (850) 575-8912 • website www.gtoinc.com

The contents of all material available on this installation manual are copyrighted by GTO, Inc. ("GTO"), unless otherwise indicated. All rights are reserved by GTO, and content may not be reproduced, downloaded, disseminated, published, or transferred in any form or by any means, except with the prior, written permission of GTO. Any reprinting of GTO publications is by permission only. Copyright infringement is a violation of federal law.

GTO®, GTO/PRO®, Mighty Mule® are registered trademarks of GTO, Inc. Professional Access Systems™ is a trademark of GTO, Inc. and are the exclusive property of GTO, Inc. ("GTO"). All rights are reserved by GTO, and these marks may not be used, in any for without the prior, written permission of GTO.